

- LEGENDA:
- VIGAS DE FUNDAÇÃO EXISTENTES
  - PILAR EXISTENTE
  - VIGA DE FUNDAÇÃO 20X35CM
  - PILAR A SER CONSTRUÍDO
  - ALVENARIA (TIJOLO 6 FUROS)
  - ALVENARIA (TIJOLO MACIÇO)
  - SAPATA TIPO 01 L80XC80XH40
  - SAPATA TIPO 02 L60XC60XH40
  - SAPATA TIPO 03 L100XC110XH40

**PILARES DE CONCRETO**  
 P18, P25, P28, P29, P30, P32, P33, P34, P36, P37, P39, P40  
 P45, P46, P47, P48, P50, P51, P52, P53, P56, P57, P58, P59, P60, P61  
 P62, P63, P64, P68, P69, P70, P71, P72, P73, P74, P75, P76, P77, P78  
 P79, P80, P82, P83

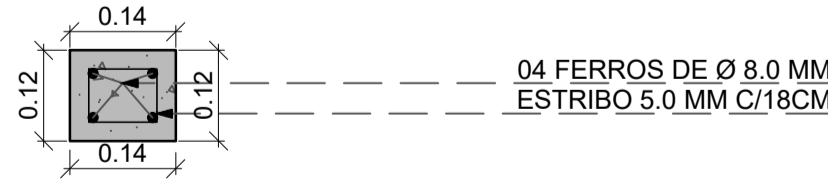

**PILARES DE CONCRETO**  
 P65, P66, P67, P81



**PILAR DE CONCRETO**  
 P26

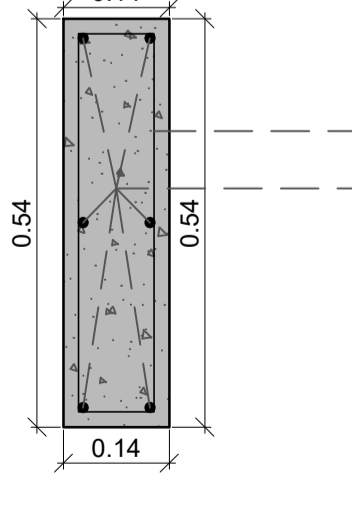

**DETALHES ESTRUTURAIS Esc: 1/10**

SAPATAS DE CONCRETO TIPO 01 L80XC80XH40

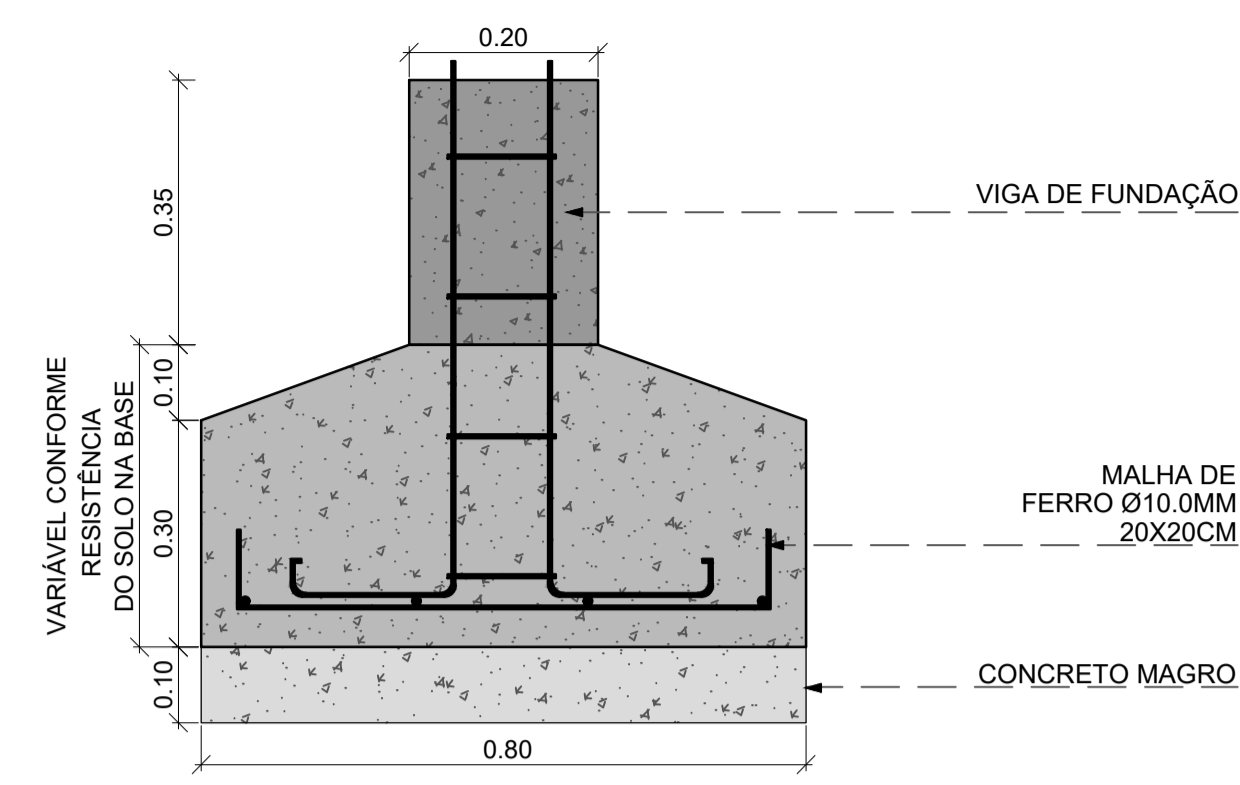

SAPATAS DE CONCRETO TIPO 02 L60XC60XH40

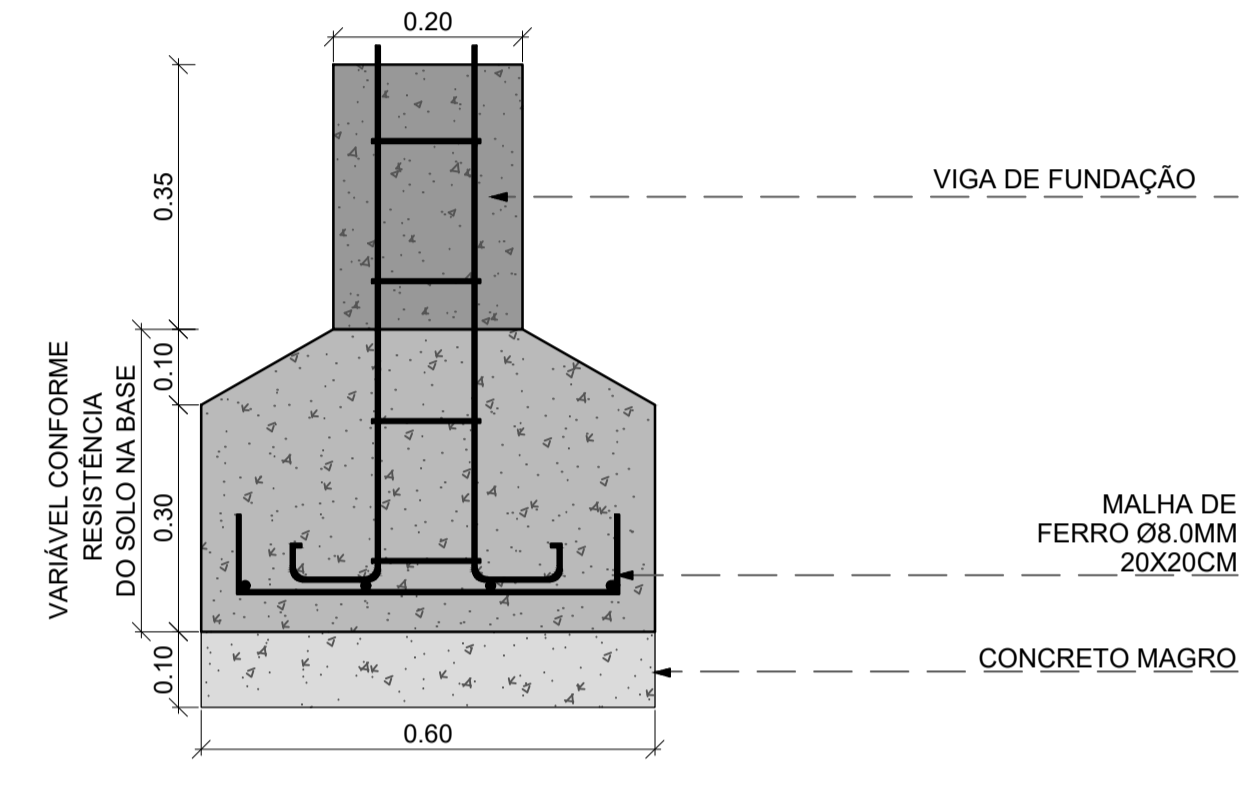

SAPATAS DE CONCRETO TIPO 03 L100XC110XH40

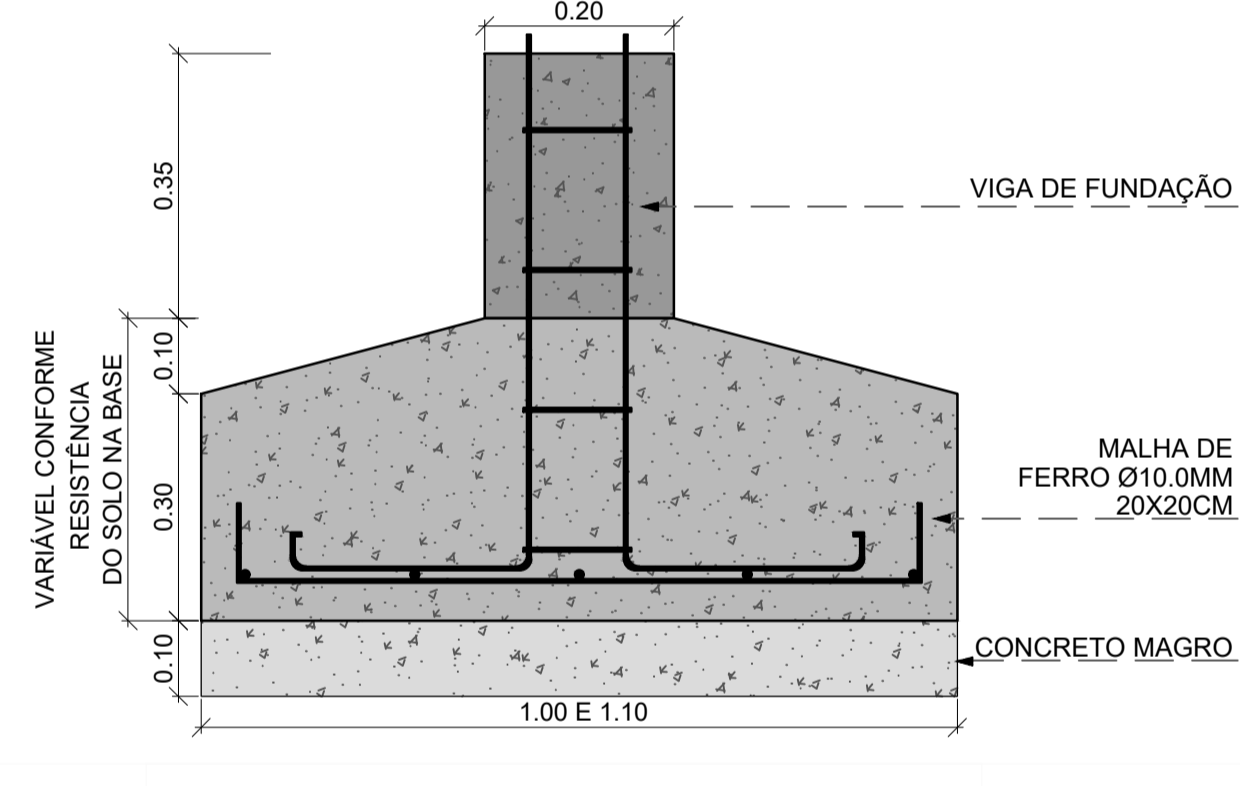

VIGA DE FUNDAÇÃO 20X35CM

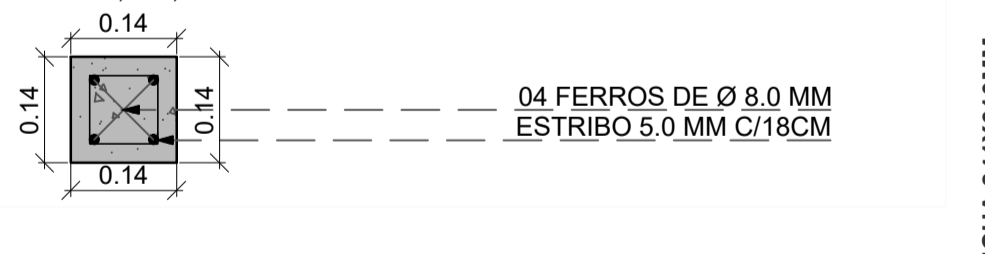
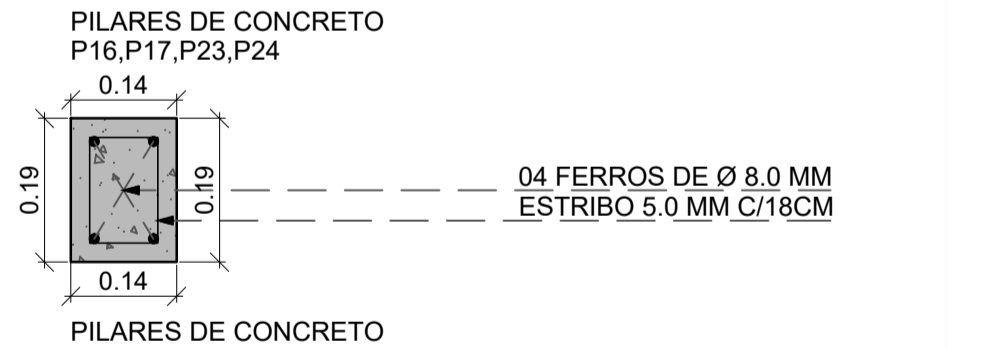
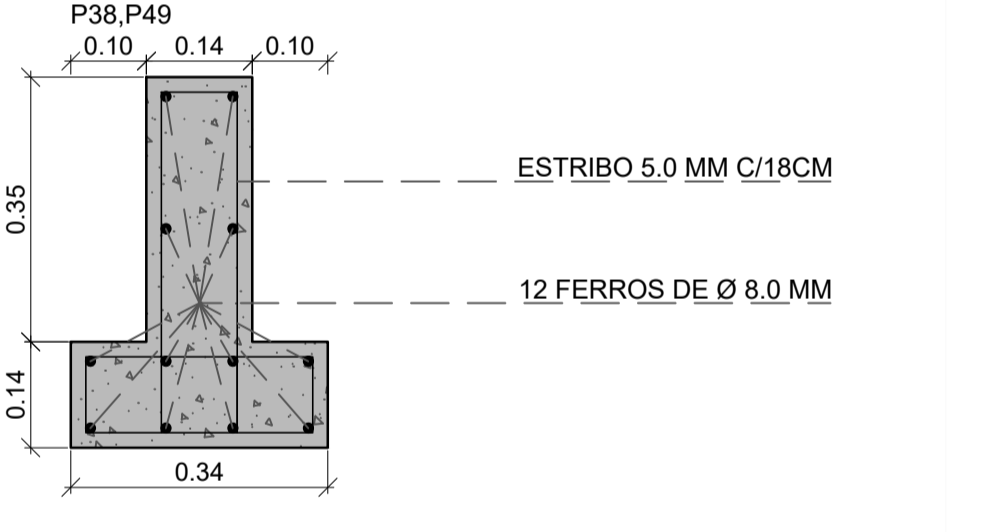
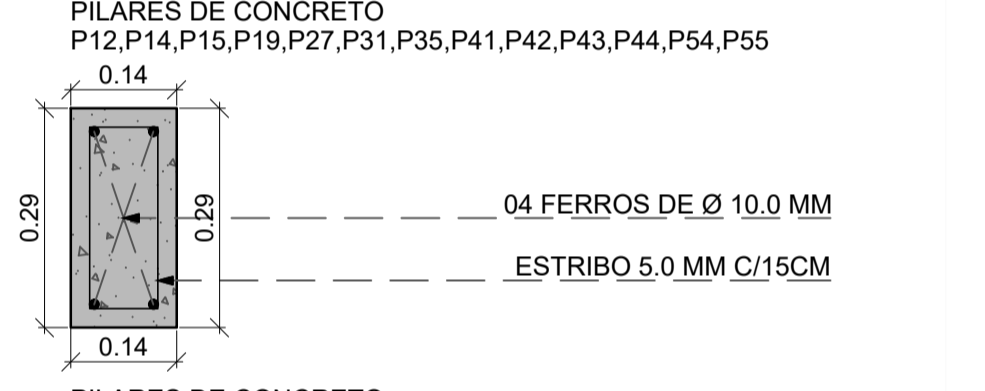
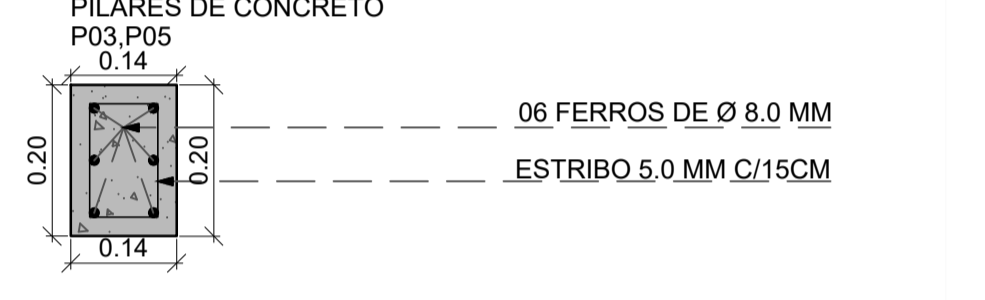
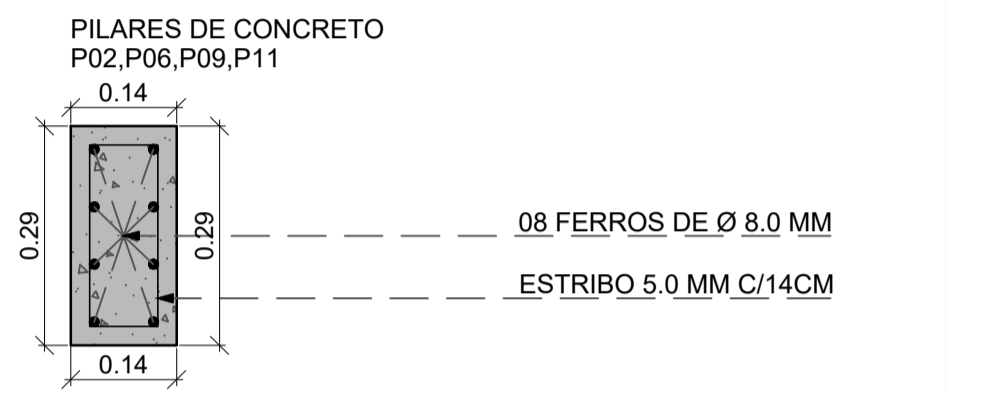
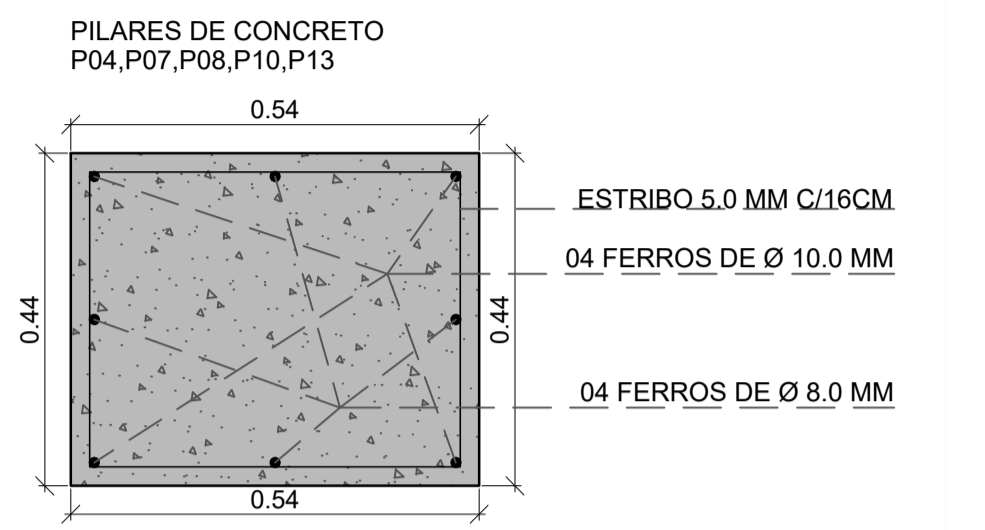
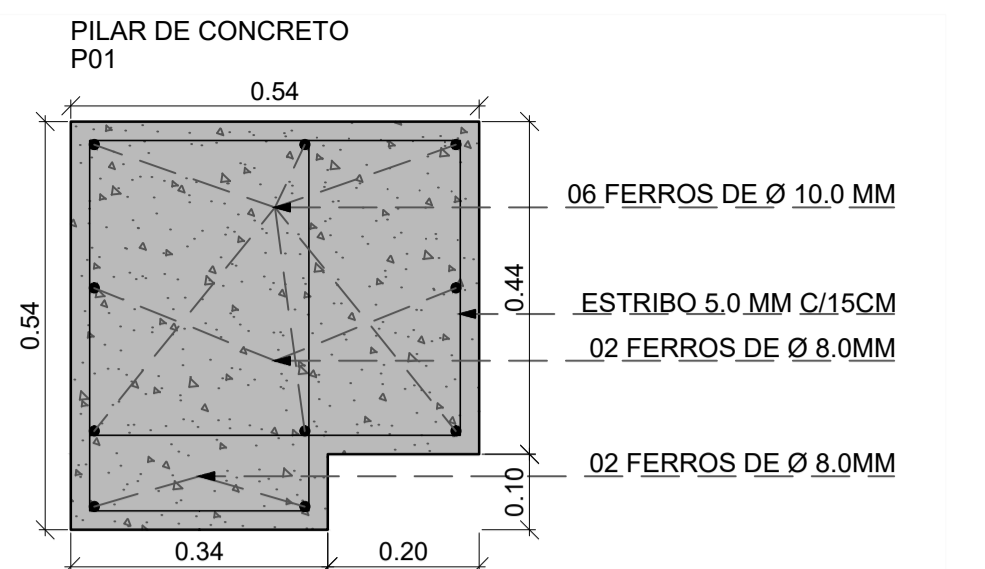
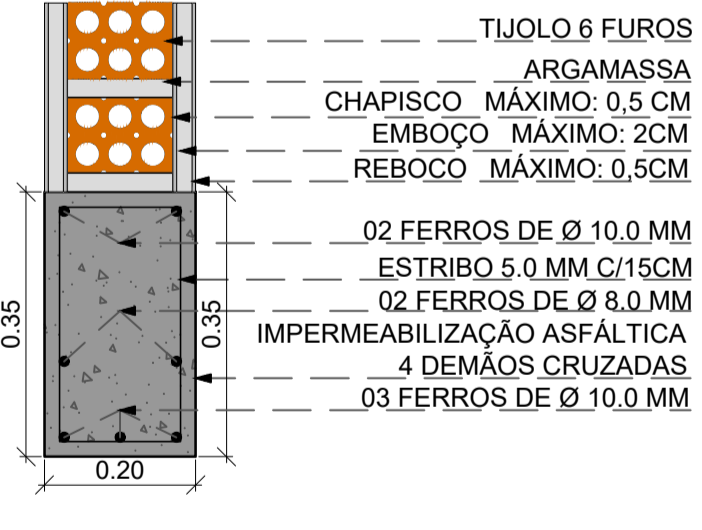

		<b>PROJETO ARQUITETÔNICO - MELHORIAS, ADEQUAÇÃO E AMPLIAÇÃO QUADRA ESPORTIVA COBERTA</b> Local: Esquina Avenida Thomaz Costa, Rua Rodolfo Stecker e Avenida Manoel de Brito - Bairro Centro - Lagoão - RS Lote nº05 - Quadra nº48 - Matrícula 14.081	
Proprietário:	<b>MUNICÍPIO DE LAGOÃO</b> CNPJ nº 92.406.289/0001-61 Prefeito Municipal: CIRANO DE CAMARGO		MAIO 2023 Escala: indicada
Responsável técnico projeto:	<b>PRISCILLA BERNARDI</b> Arquiteta e urbanista CAU-A/133317-8		Prancha: <div style="font-size: 2em; font-weight: bold; text-align: center;">03</div>
Descrição: Projeto Estrutural - Sapatas, Vigas de Fundação, Pilares e Alvenarias Detalhamentos Estruturais			Área total intervenção: 1.078,45m²